



Electrische Kettingtakel US / Electric Chain Hoist US

 Eigenschappen

- » Geschikt voor een breed scala aan industriële toepassingen.
- » Mag in geen service-auto ontbreken. Maakt uw monteur ARBO-proof.
- » Eenvoudig te bedienen en te transporteren door zijn lage gewicht.
- » Wartel lasthaak met veiligheidsklep.
- » Geleverd klaar voor gebruik met bedieningsschakelaar, voedingskabel en kettingbak.
- » Voldoet aan de Machinerichtlijn 2006/42/EG. Geleverd met testcertificaat, CE-conformiteitsverklaring en gebruiksaanwijzing.

 Features

- » Suitable for a wide range of industrial applications.
- » Should not be missing in any service van. Makes your service engineer "Health & Safety" proof.
- » Easy handling and high transportability due to low weight.
- » Swivel load hook with safety latch.
- » Supplied ready to use with control switch, power cable and chain container.
- » Complies with the Machinery Directive 2006/42/EC. Supplied with test certificate, CE declaration of conformity and operating instructions.



KARWEITAKEL®
JOBGING HOIST®

Specificaties / Specifications						
Capaciteit	Hijssnelheid	Hijsketting	Parten	Energie verbruik	Netto gewicht	Extra gewicht
Capacity	Lifting speed	Load chain	Chains falls	Power output	Net weight	Extra weight
ton	m/min	Øxmm		kW	kg	kg/m
0.5	5	6.3 x 19.1	1	1.3	16	0.9
1	2.5	6.3 x 19.1	2	1.3	17	1.8
1	4	7.1 x 20	1	2	26	1.1
2	2	7.1 x 20	2	2	31	2.2

Specificaties / Specifications	
Voltage / Operating voltage	230V / 50Hz / 1Ph (110V op aanvraag/on request)
Hijssnelheid / Lifting speed	Enkele snelheid / Single speed
Hijsketting / Load chain	Lastketting volgens EN 818-7-DT / Load chain according to EN 818-7-DT
Stuurkabel / Control cable	Standaard ≈6 meter / Standard ≈6 meter
Stroomkabel / Power cable	≈5 meter met stekker / ≈5 meter with plug
Behuizing bescherming / Housing protection	IP 54
Besturing bescherming / Control protection	IP 65
Classificatie / Classification	M4/1Am (ISO/FEM)
Inschakelduur / Starts per uur / Duty cycle / Starts per hour	30% / 180
Isolatieklasse / Insulation class	F
Bedrijfstemperatuur / Operating temperature	-10°C - +40°C
Lading type / Load type	Goederen, mag niet gebruikt worden om mensen te hijsen / Goods, may not be used to lift people

Beveiliging / Protection	
Schakelaar / Control switch	230V schakelaar met noodstop / 230V pendant control switch with emergency stop button
Overlastbeveiliging / Overload protection	Extern instelbare slipkoppeling / Externally adjustable slip clutch
Rem / Brake	Mechanische rem / Mechanical brake
Eindschakelaar / Limit switch	Geen eindschakelaar, beveiligd door slipkoppeling / No limit switch, protected through slip clutch
Thermische bescherming / Thermal protection	Geen bescherming / No protection

Electrische Ketting Takels / Electric Chain Hoists



Electrische Kettingtakel US / Electric Chain Hoist US

Optionele toebehoren / Optional accessories



10m Verlengkabel / 10m Extension cable

Om de stuurkabel te verlengen. (max. 2x per lier)
For extending the control cable. (max. 2x per winch)

Beschermhoes / Protective cover *

Voor extra bescherming tegen regen.
For extra protection against rain.

Opberg box / Storage box *

Voor eenvoudig opslag en transport.
For convenient storage and transportation.

Netto gewicht / Net weight	Afmetingen / Dimensions
kg	mm
24	670 x 580 x 480

* alleen voor US 0,5 ton & 1 ton (2,5 m/min) / only for US 0,5 ton & 1 ton (2,5 m/min)

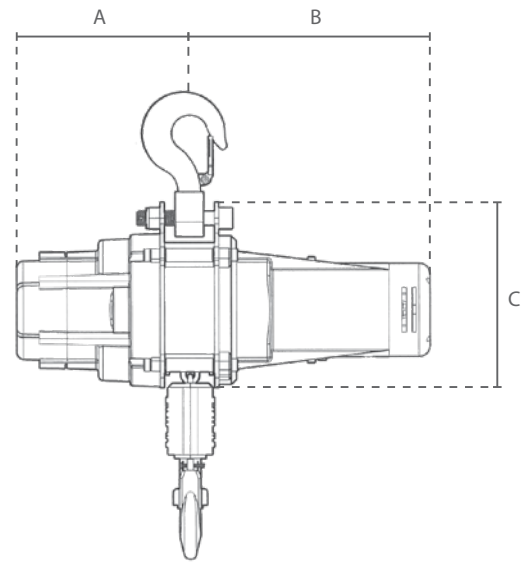
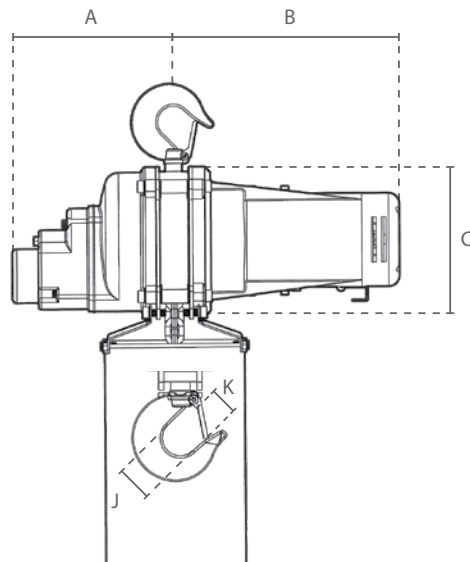
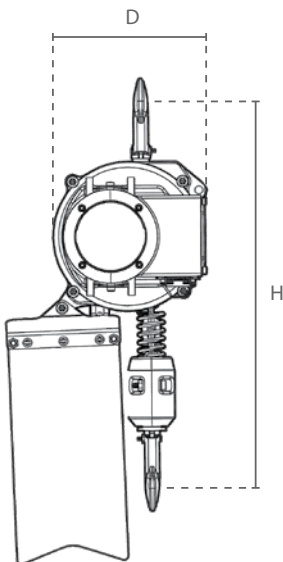

US 0,5 ton & US 1 ton (2,5 m/min)

US 1 ton (4 m/min) & US 2 ton

Artikel nummer Article code	Afmetingen / Dimensions						
	A	B	C	D	H	J	K
0,5 ton	175	245	165	160	480	38	21
1 ton (2,5 m/min)	175	245	165	160	500	38	21
1 ton (4 m/min)	191	265	206	212	500	39	29
2 ton	191	265	206	214	594	46	37